



155 to 622Mbps SFP Transceiver LR2 P/N AL23P0x-1550 (80km)



Description

Menara Networks' 155 to 622Mb/s AL23P0x-1550 SFP is designed for use in OC-3/12 SONET LR2 and STM-1/4 L-4.2 1550nm links up to 80km over 9/125µm singlemode fiber. The use of a 1550nm transmitter provides a high performance transport optic option for SONET/SDH transport. Digital Optical Monitoring interfaces are provided via the SFP SFF-8472 standards compliant I²C interface.

Applications

- 155 to 622Mb/s 80km transmission distance over 9/125µm singlemode fiber
- SONET/SDH transport

Features

- Hot-pluggable SFP footprint
- 155 to 622Mb/s bit rates
- 1550nm DFB transmitter
- Single 3.3V power supply
- Power dissipation < 1W
- 0°C to +70°C or -40°C to +85°C
- Duplex LC fiber connectors
- SONET OC-12 LR-2 compliance
- SDH STM-4 L-4.2
- Full Digital Optical Monitoring
- Metal enclosure for lower EMI
- Complies with RoHS directive (2002/95/EC)
- Compliant with SFP MSA SFF-8472 and SFF-8074
- Laser Class 1 IEC/CDRH compliant
- Links of 80km over 9/125µm singlemode fiber

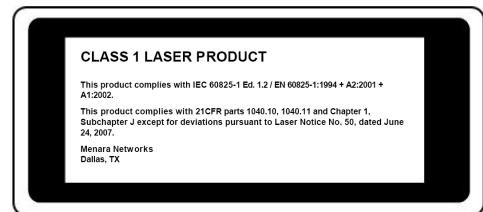
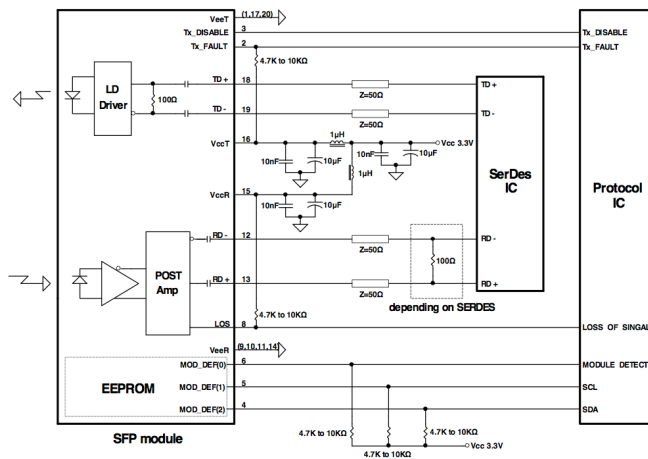

Transmitter E-O Characteristics

Parameter	Symbol	Min.	Typ.	Max.	Unit	Note
Support data rate	-	155		622	Mb/s	
Center Wavelength	λ	1480	1550	1580	nm	
Spectral Width (RMS)	$\Delta\lambda$			1	nm	
Side Mode Suppression Ratio	SMSR	30			dB	
Average Optical Output Power	P _o	-3	-	+2	dBm	1
Extinction Ratio	E _r	9			dB	
Optical Rise/Fall Time (20%~80%)	tr/tf			0.3	ns	
Data Input Swing Differential	V _{IN}	400		1800	mV	2
Input Differential Impedance	Z _{IN}	90	100	110	Ω	
TX Disable	Disable	2.0		V _{CC}	V	
	Enable	0		0.8	V	
TX Fault	Fault	2.0		V _{CC}	V	
	Normal	0		0.8	V	

1. The optical power is launched into SMF.
2. PECL input, internally AC-coupled and terminated

Receiver O-E Characteristics

Parameter	Symbol	Min.	Typ.	Max.	Unit	Note
Support data rate	-	155		622	Mb/s	
Operating Wavelength	λ	1260	-	1580	nm	
Receiver sensitivity	S _{en}			-28	dBm	3
Saturation	P _{sat}	-3			dBm	3
LOS Assert	LOS _A	-30			dBm	
LOS Deassert	LOS _D			-35	dBm	
LOS Hysteresis		1		4	dB	
Data Output Swing Differential	V _{OUT}	370		1800	mV	4
LOS	High	2.0		V _{CC}		
	Low	0		0.8	V	

3. Measured with a PRBS 2²³-1 test pattern @ 622Mbps, BER $\leq 1 \times 10^{-10}$
4. Internally AC coupled

Ordering Information

Part Number	ROHS Compliant	Operating Case Temperature
AL23P0x-1550	ROHS-6	0°C ~ +70°C
AL23P2x-1550		-40°C ~ +85°C

x = J for Juniper
x = C for Cisco
x = A for Alcatel
x = O for Cisco ONS



menarainfo@menaranet.com

www.menaranet.com