



1.25Gbps SFP Transceiver 120km 1550nm 1000BASE-EZX P/N AEZ0A0x-1550 (120km)



Description

Menara Networks' AEZ0A0x-1550 transceivers are designed for use in single channel 1550nm links up to 120km over singlemode fiber. The SFP module supports 1000BASE-EZX applications along with Fiber Channel 1x SM-LC-L FC-PI applications for Ethernet Switches or IP Router optical interfaces. Digital Optical Monitoring interfaces are provided via the SFP SFF-8472 standards compliant I²C interface.

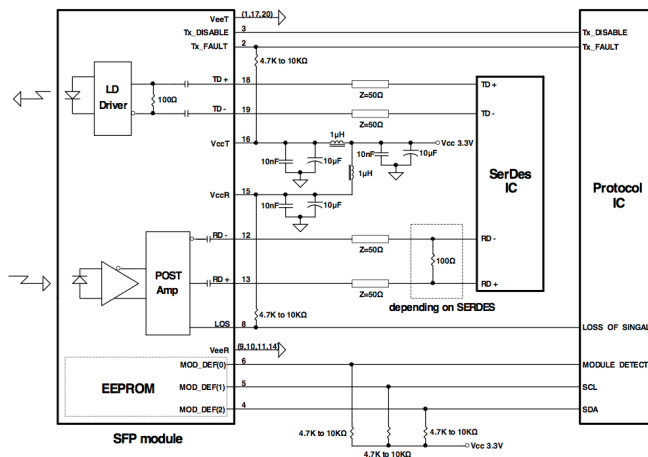

Applications

- 120km GbE or 1G FC switch transmission interconnection
- Long distance, single-channel Ethernet Switch or IP Router bandwidth expansion

Features

- Hot-pluggable SFP footprint
- Up to 1.25Gbps bit rates
- 1550nm DFB transmitter
- APD receiver
- Single 3.3V power supply
- Power dissipation < 1W
- 0°C to +70°C or -40°C to +85°C
- Duplex LC fiber connectors
- 1000BASE-ZX
- 1G FC SM-LC-L FC-PI
- Full Digital Optical Monitoring
- Metal enclosure for lower EMI
- Complies with RoHS directive (2002/95/EC)
- Compliant with SFP MSA SFF-8472 and SFF-8074
- Laser Class 1 IEC/CDRH compliant
- Links of 120km with 9/125 μm single mode fiber (SMF) of maximum interconnect distances

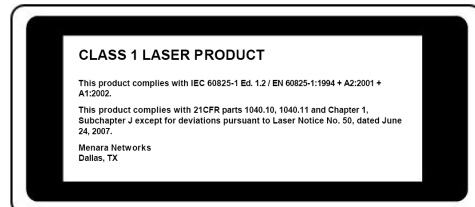

Transmitter E-O Characteristics

Parameter	Symbol	Min.	Typ.	Max.	Unit	Note
Support data rate	-	1	1.25	1.35	Gb/s	-
Center Wavelength	λ	1480	1550	1580	nm	
Spectral Width (RMS)	$\Delta\lambda$			1	nm	
Average Optical Output Power	P _o	0	-	+5	dBm	1
Extinction Ratio	ER	9			dB	
Output Eye Diagram	Compliant with IEEE 802.3					
Optical Rise/Fall Time (20%~80%)	tr/tf			0.26	ns	
Data Input Swing Differential	V _{IN}	400		1800	mV	2
Input Differential Impedance	Z _{IN}	90	100	110	Ω	
TX Disable	Disable	2.0		V _{CC}	V	
	Enable	0		0.8	V	
TX Fault	Fault	2.0		V _{CC}	V	
	Normal	0		0.8	V	

1. The optical power is launched into SMF.
2. PECL input, internally AC-coupled and terminated

Receiver O-E Characteristics

Parameter	Symbol	Min.	Typ.	Max.	Unit	Note
Support data rate	-	1	1.25	1.35	Gb/s	-
Operating Wavelength	λ	1260	-	1580	nm	3
Receiver sensitivity	S _{en}			-31	dBm	3
Saturation	P _{sat}	-9			dBm	
LOS Assert	LOS _A	-35			dBm	
LOS Deassert	LOS _D			-32	dBm	
LOS Hysteresis		0.5		4.5	dB	
Data Output Swing Differential	V _{OUT}	370		1800	mV	4
LOS	High	2.0		V _{CC}	V	
	Low	0		0.8	V	

3. Measured with a PRBS 2⁷-1 test pattern @ 1250Mbps, BER $\leq 1 \times 10^{-12}$
4. Internally AC-coupled

Ordering Information

Part Number	ROHS Compliant	Operating Case Temperature
AEZ0A0x-1550	ROHS-6	0°C ~ +70°C
AEZ0A2x-1550		-40°C ~ +85°C

x = J for Juniper
x = C for Cisco
x = A for Alcatel
x = O for Cisco ONS



menarainfo@menaranet.com

www.menaranet.com